



## KEYSTONE

### Features and Benefits

- Uninterrupted gasket surfaces eliminate problems associated with seat retaining screws in the gasket surface and allows use of standard spiral wound gaskets.
- Unique interference seat design with energized elastomer O-ring allows bi-directional ANSI Class VI shutoff at lower pressures. The seat is further energized by line pressure, providing the same tight bi-directional shutoff at full-rated pressure.
- Heavy duty circular key holds the seat and retaining ring in place, providing bi-directional, dead-end service at full-rated pressure. This eliminates the need for easily corroded and hard-to-remove retention screws.
- Valve stem designed to API 609 standards is blow-out resistant.
- Seat retaining ring is housed within the flange gasket ID to eliminate potential emission path.
- Face-to-face conforms to MSS-SP-68 and can be configured to ISO 5752 short.
- Adjustable packing utilizes unique rocker-shaped gland bridge that compensates for uneven adjustment of gland nuts. Optional non-adjustable packing offers an economical alternative.
- Extended neck allows for two inches of clearance for insulation.

## K-LOK® High Performance Butterfly Valve Sizes 2 thru 12-inch ANSI Class 150

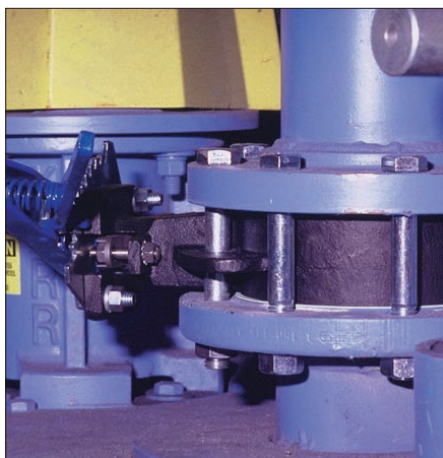

### General Application

High performance applications such as steam, chill water, water, utility lines, gasoline, natural gas, air, oil, jet fuels and process lines. Consult factory for appropriate materials for specific services.

### Technical Data

Size Range	: 2 thru 12-inch [50 thru 300 mm]
Rating	: ANSI Class 150

### Materials of Construction

Body	: Carbon Steel 316 SS
Disc/Stem	: 316 SS/17-4PH 316 SS/316 SS
Seat	: RTFE or PTFE with FEP Encapsulated FKM* O-ring as standard
Stem Bearings	: 316 SS body SS/DU
Carbon steel body	: Carbon Steel/DU
Pressure Rating	: 285 psi bi-directional, dead-end
Temperature Rating	: Standard -20°F to 350°F

# Keystone K-LOK Figure 310/312

## High Performance Butterfly Valve

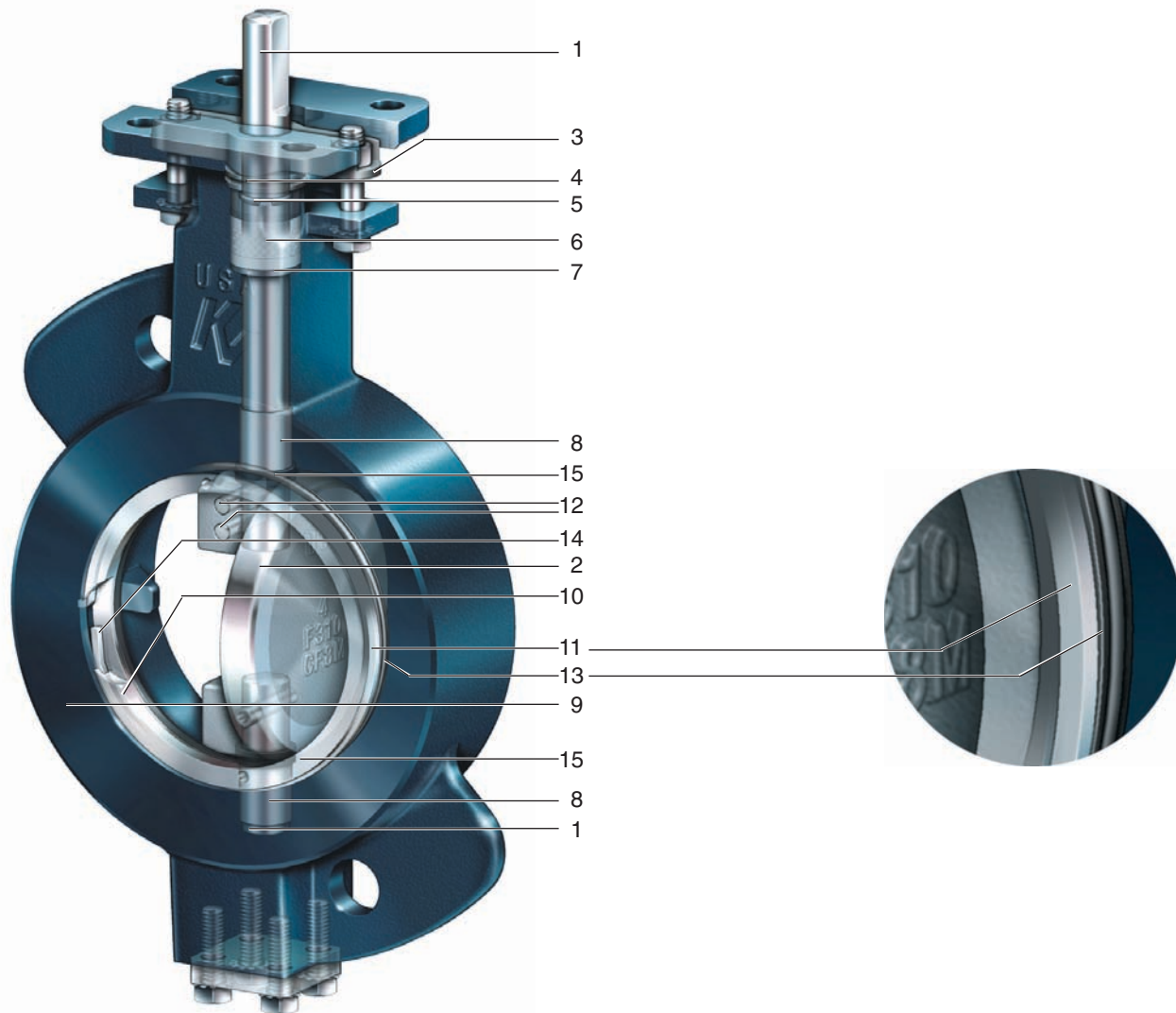

Materials			
Part	Material	Material Standard	Optional Material
1 Stem	17-4PH	ASTM A 564 Cond. H1075 or H 1100	316 SS Cond. B
2 Disc	316 SS	ASTM A 351-CF8M	
3 Gland bridge	17-4SS HT		
4 Packing gland follower	316 SS	ASTM A 276-316	
5 Blowout-resistant ring			
6 Packing	TFE		
7 Anti-extrusion ring	316 SS	ASTM A 276-316	
8 Bearings	CS/DU SS/DU	TFE impregnated TFE impregnated	
9 Body	CS SS	ASTM A216-WCB ASTM A351-CF8M	
10 Seat retaining ring	CS SS	ASTM A36 ASTM A240	
11 Seat	RTFE	Reinforced polytetrafluoroethylene	PTFE
12 Wedge pins	17-4PH		316 SS Cond. B
13 Seat backing O-ring		FEP* Encapsulated FKM	FKM, Nitrile, EPDM
14 Circular key	SS	ASTM A240	
15 Thrust bearing	SS		

\*Fluorinated ethylene / Propylene fluoro plastics

### Principles of Design

K-LOK is an ideal control valve designed to provide an inherent equalinear characteristic that is suitable for most linear and equal percentage applications. The valve offers a high flow capacity, thin profile disc with a rangeability of 33:1. The use of tangentially located disc/stem wedge pins removes engagement clearances and eliminates valve hysteresis.

While the valve is throttling, the stem's double offset location causes the disc to cam away from the seat, reducing wear and deformation. When the disc closes, a drop tight seal is assured. (See page 4 for additional information.)

### Design Features

**Stem (1)** is manufactured from materials that provide maximum strength and stability. The stem surface is finished to Ra 29 for maximum sealing interface between the stem and the packing.

**Gland bridge (3)** incorporates a rocker shape to compensate for uneven adjustment of the gland nuts. The upper gland nuts are captured in the bridge for ease of maintenance.

**Packing gland follower (4)** has a circular groove for easy field removal.

**Blowout-resistant ring (5)** is standard on all Figure 310/312 valves.

**Packing (6)** utilizes a combination of force-dried, soft-braided rings and solid TFE 'V' rings to provide a superior stem seal. Non-adjustable packing option is also available.

**Bearings (8)** of press fit steel or stainless steel are located near the disc to minimize the possibility of deflection.

**Body (9)** features an extended neck that allows for two inches of insulation and integral cast travel stop. Non-interrupted flange gasket surfaces allow for the use of standard spiral wound gaskets.

**Seat retaining ring (10)** is located within the flange gasket ID. This allows for an uninterrupted flange sealing surface and maximum emissions control.

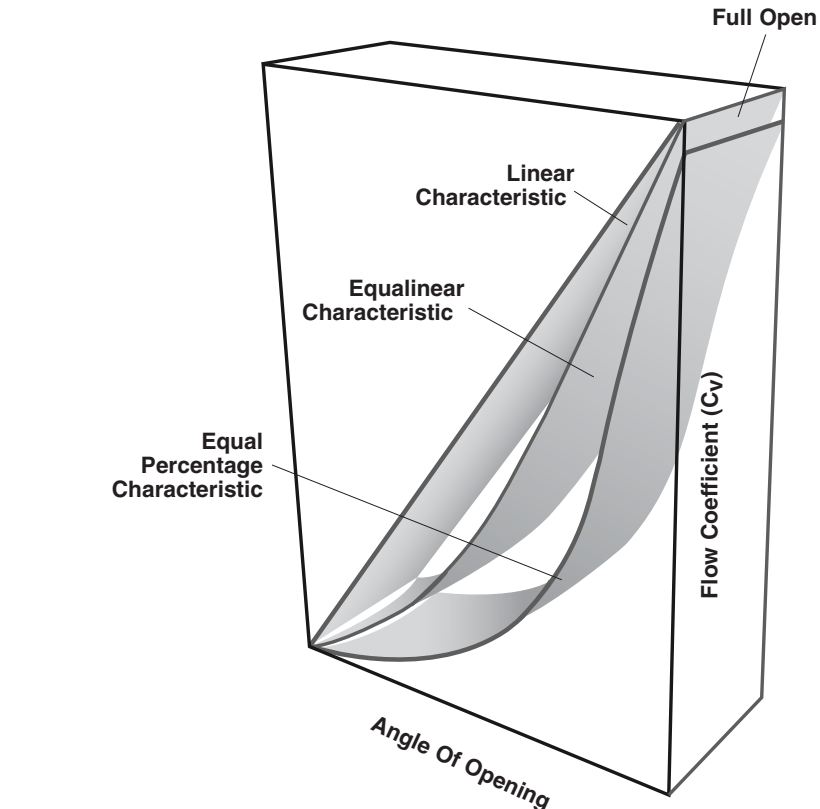

### Vacuum 50 microns to Low Pressure

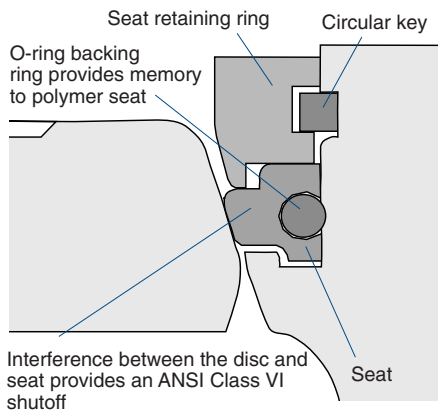

### Medium to High Pressure

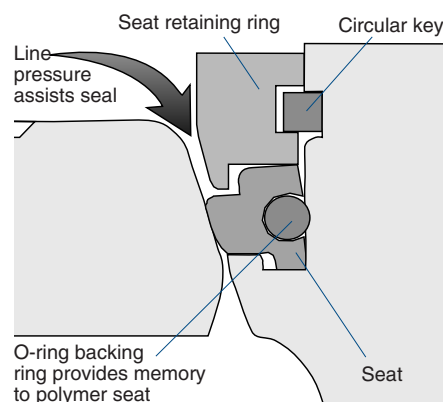

**Seat (11)** is an advanced patented bi-directional dual-lock seat design\* that provides an interference disc/seat seal at vacuum-to-low pressures and utilizes line pressure to achieve maximum sealability at medium-to-high pressures.

**Wedge pins (12)** are tangentially located for maximum strength and then welded in place after final assembly and testing.

**Seat backing O-ring (13)** is available in a variety of materials to meet customer requirements. (Materials and

applications are listed on page 8.)

**Circular key (14)** provides bi-directional, dead-end service at full-rated pressure. Removable in the field for quick seat replacement.

Integrally cast mounting pad allows direct mounting of Keystone actuators.

Flange location holes allow precise alignment of valve between pipe flanges during installation.

\*Patented

### Disc and seat design

K-LOK disc geometry maximizes flow capacity by increasing the available flow area through the valve. This increase in disc efficiency results in a high valve  $C_v$ .

#### Two-piece stem vs. one-piece stem

The improved  $C_v$  may be easily explained by comparing the aspect ratio of the K-LOK two-piece stem and disc arrangement to that of a through-stem design. This unique disc configuration provides a universal inherent flow characteristic which is referred to as equalinear.

#### Double offset disc/stem

The K-LOK design uses a double offset disc/stem design. The first offset is achieved by locating the stems downstream of the centerline of the seat. This allows for a total unobstructed 360 degrees sealing surface.

The second offset locates the stems off the center of the vertical axis of the seat.

The combination of these two offsets creates a camming effect as the disc swings into and out of the seat. The disc lifts quickly out of the seat in the first few degrees of travel and does not contact the seat again until it is nearly closed. There is no wear point between the seat and disc, so operating torques are reduced and seat life is extended.

#### Vacuum rating

The combination of interference fit seats and bi-directional packing makes the K-LOK especially well suited for vacuum service.

Standard K-LOK F310/312 high performance valves are rated to an absolute pressure of 50 microns.

### First Offset

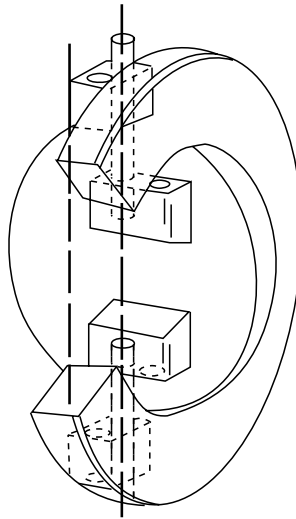

### Second Offset

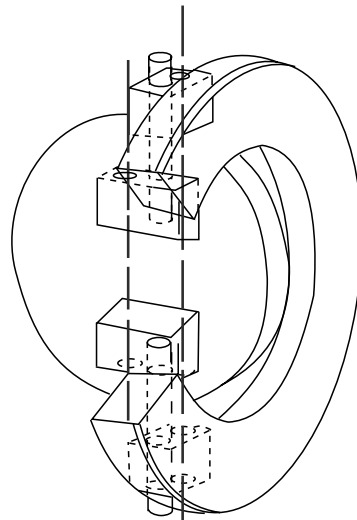

### Double Offset

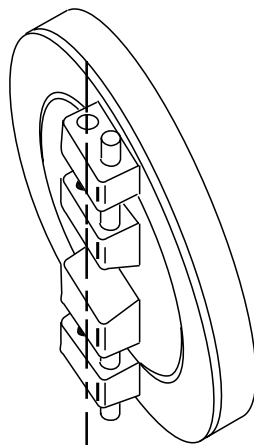

Competitor:  
with one-piece stem

K-LOK:  
with two-piece stem

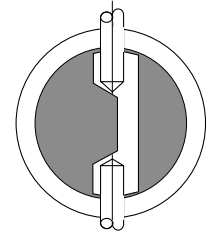
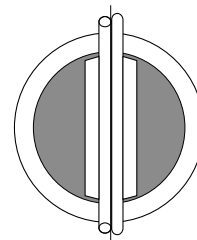

Aspect Ratio = Open Area ÷ Disc Area

### Stem Packing Design

Adjustable  
Braided  
Packing

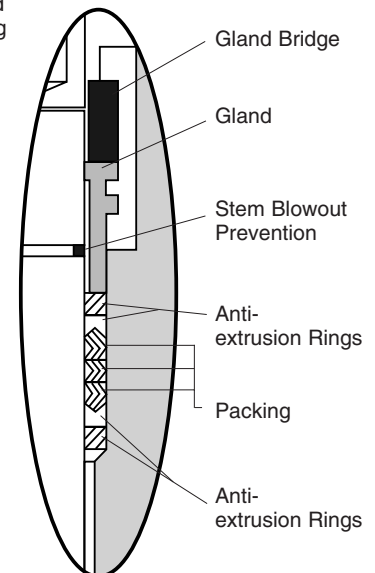

**C<sub>v</sub> Valves vs. Travel Position**

Size (in.)	Angle of Opening								
	10°	20°	30°	40°	50°	60°	70°	80°	90°
2	0	4	14	25	35	42	46	50	52
2½	0	12	26	47	72	95	121	137	142
3	0	14	30	53	82	111	142	161	168
4	11	39	79	123	183	260	347	443	496
5	24	66	133	202	295	425	574	755	859
6	32	85	170	255	371	538	729	968	1,106
8	36	148	302	457	677	1,016	1,423	2,034	2,344
10	41	221	455	691	1,032	1,571	2,228	3,271	3,781
12	45	288	596	907	1,358	2,082	2,968	4,409	5,102

**Pressure/Temperature Rating For Backing Ring Materials**

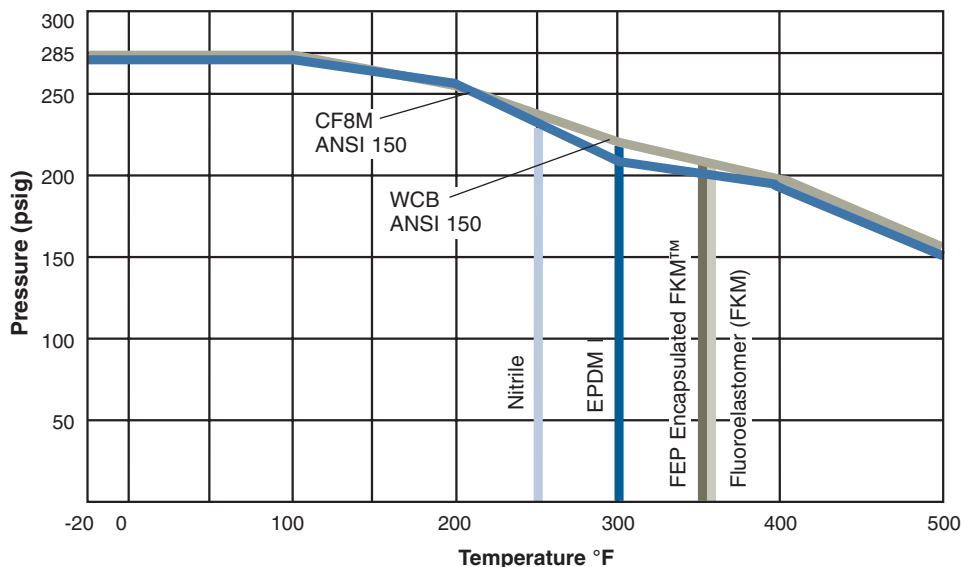

**PTFE and RTFE Bi-Directional Seating and Un-seating Torque Values**

Size (in.)	Shaft Mounting Code	Seating and Un-seating Torque (lbs. in.) System Shutoff Pressure (psig)						
		0	50	100	150	200	250	285
2	BBG	92	101	109	118	126	135	141
2½	BAC	122	138	155	171	188	204	216
3	BAC	133	153	173	193	213	232	246
4	BAC	260	296	333	369	406	442	468
5	BAD	327	411	495	579	664	748	807
6	BAD	448	563	677	792	906	1,021	1,101
8	CAE	386	646	905	1,165	1,425	1,684	1,866
10	CAF	678	1,119	1,560	2,000	2,441	2,882	3,191
12	CAF	970	1,604	2,238	2,873	3,507	4,141	4,585

**Notes**

- Torques are applicable to PTFE and RTFE seats.
- For other service conditions, select the torque applicable for the maximum differential pressure and multiply by the following factor:  
 Water : x 1.0  
 Lubricious Service : x 0.75  
 Dry Service : x 1.9

**Seating and Un-seating Torque**

Seating and un-seating torques are a function of the size of the valve and the shutoff pressure of the system.

Specific torque ratings can be found in the Seating/Un-seating chart at the intersection of the 'size' row and the 'shutoff pressure' column.

All torques listed are for normal service conditions (i.e. operating frequency is a minimum of once per month; disc corrosion is expected to be mild or minor, the media is a clean gas, liquid or steam, and is non-abrasive) and the chemical effects upon the seat are minor.



# Keystone K-LOK Figure 310/312

High Performance Butterfly Valve

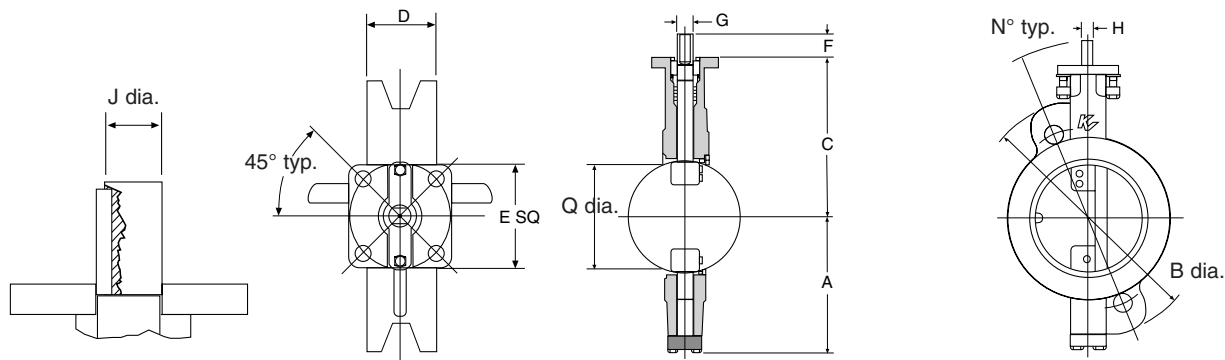

## Wafer Style

Size (in.)	Valve Dimensions MSS											Top Plate Drilling				Weight (lbs.)	Adapt. Code
	A	B	C	Q	E	D	F	G	H	J	N	KEY	Bolt Circle	No. Holes	Hole Dia.		
2	3.73	6 <sup>3</sup> / <sub>8</sub>	4.94	1 <sup>15</sup> / <sub>16</sub>	3 <sup>3</sup> / <sub>8</sub>	1.69	0.86	1/2	3/8	N/A	45°	N/A	3 <sup>1</sup> / <sub>4</sub>	4	7/16	8	BBG
2 <sup>1</sup> / <sub>2</sub>	4.12	7 <sup>3</sup> / <sub>16</sub>	5.39	2 <sup>5</sup> / <sub>16</sub>	3 <sup>3</sup> / <sub>16</sub>	1.88	1.22	5/8	7/16	N/A	45°	N/A	3 <sup>1</sup> / <sub>4</sub>	4	7/16	9	BAC
3	4.60	7 <sup>7</sup> / <sub>8</sub>	5.73	2 <sup>7</sup> / <sub>8</sub>	3 <sup>3</sup> / <sub>16</sub>	1.88	1.22	5/8	7/16	N/A	45°	N/A	3 <sup>1</sup> / <sub>4</sub>	4	7/16	12	BAC
4	5.21	9 <sup>1</sup> / <sub>4</sub>	6.71	3 <sup>13</sup> / <sub>16</sub>	3 <sup>3</sup> / <sub>16</sub>	2.12	1.22	5/8	7/16	N/A	22.5°	N/A	3 <sup>1</sup> / <sub>4</sub>	4	7/16	19	BAC
5	6.28	10 <sup>7</sup> / <sub>8</sub>	7.28	4 <sup>13</sup> / <sub>16</sub>	3 <sup>3</sup> / <sub>16</sub>	2.25	1.22	3/4	1/2	N/A	22.5°	N/A	3 <sup>1</sup> / <sub>4</sub>	4	7/16	25	BAD
6	6.95	12 <sup>3</sup> / <sub>16</sub>	8.01	5 <sup>3</sup> / <sub>4</sub>	3 <sup>3</sup> / <sub>16</sub>	2.25	1.22	3/4	1/2	N/A	22.5°	N/A	3 <sup>1</sup> / <sub>4</sub>	4	7/16	31	BAD
8	7.97	14 <sup>1</sup> / <sub>4</sub>	9.41	7 <sup>5</sup> / <sub>8</sub>	4 <sup>5</sup> / <sub>8</sub>	2.50	1.22	7/8	5/8	N/A	22.5°	N/A	5	4	9/16	50	CAE
10	9.39	16 <sup>3</sup> / <sub>4</sub>	10.83	9 <sup>9</sup> / <sub>16</sub>	4 <sup>5</sup> / <sub>8</sub>	2.81	2	1 <sup>1</sup> / <sub>8</sub>	N/A	0.98	15°	1/4 x 1/4	5	4	9/16	68	CAF
12	10.55	19 <sup>5</sup> / <sub>16</sub>	12.07	11 <sup>3</sup> / <sub>8</sub>	4 <sup>5</sup> / <sub>8</sub>	3.19	2	1 <sup>1</sup> / <sub>8</sub>	N/A	0.98	15°	1/4 x 1/4	5	4	9/16	99	CAF

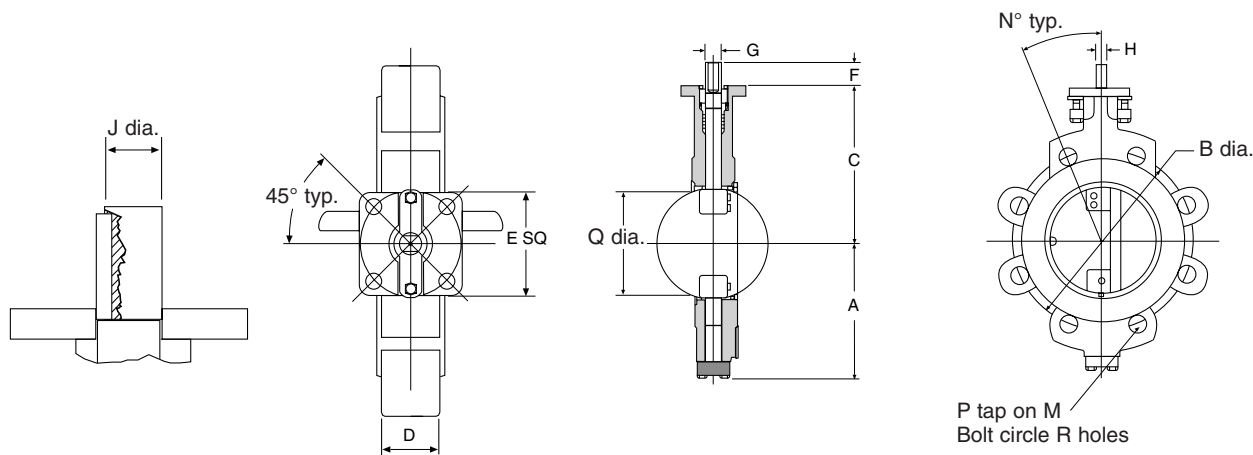

## Lug Style

Size (in.)	Valve Dimensions MSS											Tapped Lug Data			Top Plate Data			Weight (lbs.)	Adapt. Code
	A	B	C	Q	E	D	F	G	H	J	N	M	P	R	Bolt Circle	No. Holes	Hole Dia.		
2	3.73	6 <sup>1</sup> / <sub>4</sub>	4.94	1 <sup>15</sup> / <sub>16</sub>	3 <sup>3</sup> / <sub>16</sub>	1.69	0.86	1/2	3/8	N/A	45°	4.750	5/8 - 11UNC-2B	4	3 <sup>1</sup> / <sub>4</sub>	4	7/16	12	BBG
2 <sup>1</sup> / <sub>2</sub>	4.12	7	5.39	2 <sup>5</sup> / <sub>16</sub>	3 <sup>3</sup> / <sub>16</sub>	1.88	1.22	5/8	7/16	N/A	45°	5.500	5/8 - 11UNC-2B	4	3 <sup>1</sup> / <sub>4</sub>	4	7/16	15	BAC
3	4.60	7 <sup>1</sup> / <sub>2</sub>	5.73	2 <sup>7</sup> / <sub>8</sub>	3 <sup>3</sup> / <sub>16</sub>	1.88	1.22	5/8	7/16	N/A	45°	6.000	5/8 - 11UNC-2B	4	3 <sup>1</sup> / <sub>4</sub>	4	7/16	18	BAC
4	5.21	10	6.71	3 <sup>13</sup> / <sub>16</sub>	3 <sup>3</sup> / <sub>16</sub>	2.12	1.22	5/8	7/16	N/A	22.5°	7.500	5/8 - 11UNC-2B	8	3 <sup>1</sup> / <sub>4</sub>	4	7/16	32	BAC
5	6.28	11	7.28	4 <sup>13</sup> / <sub>16</sub>	3 <sup>3</sup> / <sub>16</sub>	2.25	1.22	3/4	1/2	N/A	22.5°	8.500	3/4 - 10UNC-2B	8	3 <sup>1</sup> / <sub>4</sub>	4	7/16	40	BAD
6	6.95	11 <sup>3</sup> / <sub>4</sub>	8.01	5 <sup>3</sup> / <sub>4</sub>	3 <sup>3</sup> / <sub>16</sub>	2.25	1.22	3/4	1/2	N/A	22.5°	9.500	3/4 - 10UNC-2B	8	3 <sup>1</sup> / <sub>4</sub>	4	7/16	46	BAD
8	7.97	13 <sup>1</sup> / <sub>2</sub>	9.41	7 <sup>5</sup> / <sub>8</sub>	4 <sup>5</sup> / <sub>8</sub>	2.50	1.22	7/8	5/8	N/A	22.5°	11.750	3/4 - 10UNC-2B	8	5	4	9/16	69	CAE
10	9.39	16 <sup>15</sup> / <sub>16</sub>	10.83	9 <sup>9</sup> / <sub>16</sub>	4 <sup>5</sup> / <sub>8</sub>	2.81	2	1 <sup>1</sup> / <sub>8</sub>	N/A	0.98	15°	14.250	7/8 - 9UNC-2B	12	5	4	9/16	121	CAF
12	10.55	19	12.07	11 <sup>3</sup> / <sub>8</sub>	4 <sup>5</sup> / <sub>8</sub>	3.19	2	1 <sup>1</sup> / <sub>8</sub>	N/A	0.98	15°	17.000	7/8 - 9UNC-2B	12	5	4	9/16	159	CAF

# Keystone K-LOK Figure 310/312

High Performance Butterfly Valve

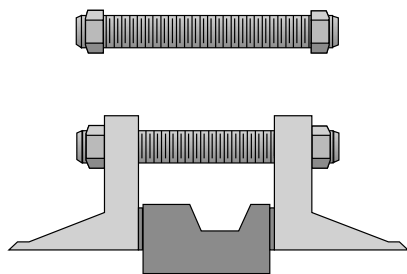

## 310 Wafer - Recommended Flange Bolt Lengths

Size (in.)	Qty.	Bolt Size	Lengths of Fasteners (in.)	
			Bolts	All-thread Studs
2	4	5/8 - UNC	4 1/2	5
2 1/2	4	5/8 - UNC	4 1/2	5
3	4	5/8 - UNC	4 1/2	5 1/4
4	8	5/8 - UNC	4 3/4	5 1/2
5	8	3/4 - UNC	5	6
6	8	3/4 - UNC	5 1/4	6
8	8	3/4 - UNC	5 3/4	6 1/2
10	12	7/8 - UNC	6 1/4	7 1/4
12	12	7/8 - UNC	7	7 3/4

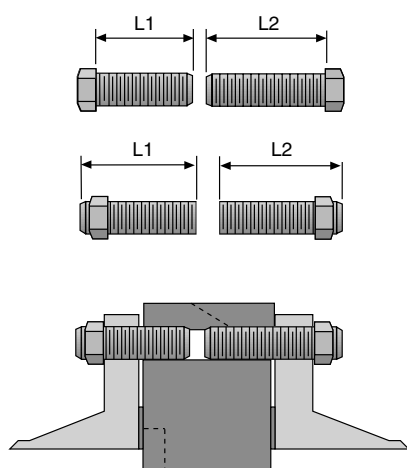

## 312 Lug - Recommended Flange Bolt Lengths

Size (in.)	Qty.	Bolt Size	Length of fasteners (in.)			
			Up Stream Side - L1		Down Stream Side - L2	
			Bolts	All-thread Studs	Bolts	All-thread Studs
2	4	5/8 - UNC	1 1/2	2 1/2	1 3/4	2 1/2
2 1/2	4	5/8 - UNC	1 3/4	2 1/2	2	2 1/2
3	4	5/8 - UNC	1 3/4	2 1/2	2	2 3/4
4	8	5/8 - UNC	1 3/4	2 1/2	2	2 3/4
5	8	3/4 - UNC	2	3	2 1/4	3
6	8	3/4 - UNC	2	3	2 1/4	3 1/4
8	8	3/4 - UNC	2	3	2 1/4	3 1/4
10	12	7/8 - UNC	2 1/4	3 1/2	2 1/2	3 3/4
12	12	7/8 - UNC	2 1/2	3 3/4	2 3/4	4

### Note

Bolt lengths are based on ANSI Class 150 weld neck flanges per ANSI B16.5 and a gasket thickness of 0.062 inch.

## Optional Flange Standards

Standard	Size (in.)																	
	2		2 1/2		3		4		5		6		8		10		12	
	310	312	310	312	310	312	310	312	310	312	310	312	310	312	310	312	310	312
ANSI 300	Y	N	Y	N	Y	N	Y	Y	Y	Y	Y	N	Y	N	Y	N	Y	N
DIN 2632 PN-10	Y	Y	Y	Y	Y	N	Y	Y	Y	Y	Y	Y	Y	Y	Y	Y	Y	Y
DIN 2633 PN-16	Y	Y	Y	Y	Y	N	Y	Y	Y	Y	Y	Y	Y	N	Y	Y	Y	Y
DIN 2634 PN-25	Y	Y	Y	N	Y	N	Y	Y	Y	Y	Y	Y	Y	N	Y	Y	Y	N
JIS B 2212 10K	Y	Y	Y	Y	Y	N	Y	Y	Y	Y	Y	Y	Y	N	Y	Y	Y	N
JIS B 2213 16K	Y	N	Y	N	Y	N	Y	Y	Y	Y	Y	N	Y	N	Y	Y	Y	N

### Notes

- Optional flange standard must be specified at time of order.
- Valve is rated to 285 psi. Do not exceed pressure rating.

### Seat O-ring Material Applications

#### FEP Encapsulated FKM

Temperature Range -20°F to 350°F

##### Generally shows good resistance to:

Acids  
Steam  
Bleaches  
Ozone  
Pulp & paper liquors  
Sour (H<sub>2</sub>S) oil and gas  
Alcohols  
Aromatics  
Brines  
Oxidizing agents  
Hexones  
Caustics

##### Generally shows poor resistance to:

Hydrofluoric acid

#### Fluoroelastomer (FKM)

Temperature Range -20°F to 350°F

##### Generally shows good resistance to:

Acids  
Aliphatic hydrocarbons  
Animal and vegetable oils  
Gasoline and kerosene  
Naptha  
Silicone fluids and greases  
Petroleum oils  
Aromatic hydrocarbons  
Fuel oils  
Natural and LP gas  
Ozone  
Organic and inorganic acids

##### Generally shows poor resistance to:

Aldehydes  
Anhydrous ammonia  
Ethers  
Amines  
Ketones  
Hot water

#### NITRILE (NBR)

Temperature Range -20°F to 250°F

##### Generally shows good resistance to:

Alcohols  
Aliphatic hydrocarbons  
Aromatic hydrocarbons  
Animal and vegetable oils  
Chemicals  
Di-ester based lubricants  
Ethylene glycol based fluid  
Hydraulic fluids  
Gasoline and kerosene  
Naphtha  
Natural and LP gas  
Petroleum oils  
Silicone fluids and greases  
Steam

##### Generally shows poor resistance to:

Aldehydes  
Amines  
Chlorinated hydrocarbons  
Halogenated hydrocarbons  
Low molecular weight esters  
Ketones  
Ethers  
Ozone  
Strong acids

#### EPDM

Temperature Range -20°F to 300°F

##### Generally shows good resistance to:

Alcohols  
Aldehydes  
Alkalines  
Amines-(UDMH)  
Animal oils  
Concentrated acids  
Chemicals  
Most esters  
Ketones (MEK, Acetone)  
Ozone  
Nitrogen derivatives  
Silicone fluids and greases  
Steam