



Socket Weld End Ball Valves

2011N

1000 W.O.G. / PN 63 3-PIECE FULL PORT

VMTM2011NR SS or CS



FEATURES

- Investment casting
- Blow-out proof stem
- Lock device handle
- TA-Luft approved
- The socket weld end conform to ANSI B16.11
DIN 3239 part 2

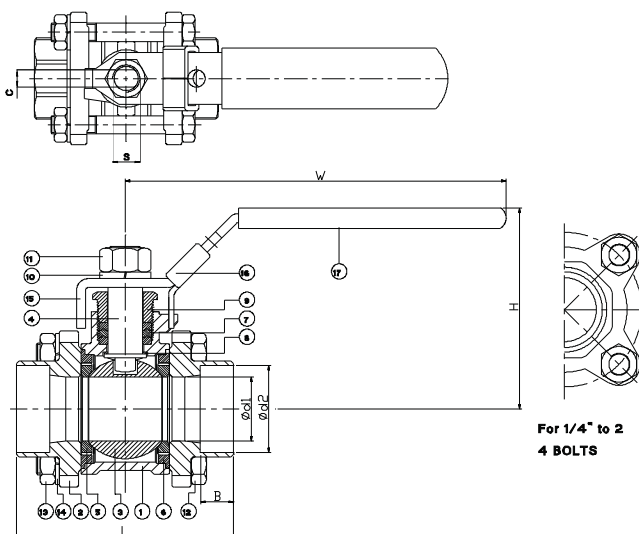

ITEM	PARTS	MATERIAL
1	BODY	ASTM A216-WCB
2	CAP	
3	BALL	ASTM A351-CF8M
4	STEM	ASTM A276-316
5	BALL SEAT	PTFE
6	BODY SEAL	
7	PACKING	
8	THRUST WASHER	AISI 304
9	GLAND NUT	
10	SPRING WASHER	
11	STEM NUT	
12	BOLT	
13	NUT	
14	SPRING WASHER	
15	HANDLE	
16	LOCK DEVICE	
17	HANDLE SLEEVE	

	1000WOG									Torque (N·M)	Weight (kg)
	DN	d1	d2	B	L	H	W	C	S		
PN63	8	11.6	14.5	10	65	58.5	100	5	3/8"-24UNF	3.5	0.35
	10	12.5	18	10	65	58.5	100	5	3/8"-24UNF	4	0.35
	15	15	22	10	65	62	100	5	3/8"-24UNF	5.5	0.5
	20	20	27.5	13	75	62	125	6.5	7/16"-20UNF	7.5	0.7
	25	25	34	13	85	77	149	7.9	7/16"-20UNF	11	1
	32	32	43	13	101	82	149	7.9	7/16"-20UNF	15	1.6
	40	38	49	13	112	100	190	10	1/2"-20UNF	20	2.5
50	50	61	16	130	108	190	10	1/2"-20UNF	40	3.5	
unit:mm											
	1000WOG									Torque (in·lb)	Weight (lb)
	NPS	d1	d2	B	L	H	W	D	M		
	1/4"	0.46	0.57	0.39	2.56	2.3	3.94	0.2	3/8"-24UNF	31.0	0.77
	3/8"	0.49	0.71	0.39	2.56	2.3	3.94	0.2	3/8"-24UNF	35.4	0.77
	1/2"	0.59	0.87	0.39	2.56	2.44	3.94	0.2	3/8"-24UNF	48.7	1.1
	3/4"	0.79	1.08	0.51	2.95	2.44	4.92	0.26	7/16"-20UNF	66.4	1.54
	1"	0.98	1.34	0.51	3.35	3.03	5.87	0.31	7/16"-20UNF	97.4	2.2
	1-1/4"	1.26	1.69	0.51	3.98	3.23	5.87	0.31	7/16"-20UNF	132.8	3.53
1-1/2"	1.5	1.93	0.51	4.41	3.94	7.48	0.39	1/2"-20UNF	177	5.51	
2"	1.97	2.4	0.63	5.12	4.25	7.48	0.39	1/2"-20UNF	354	7.72	
unit:in											

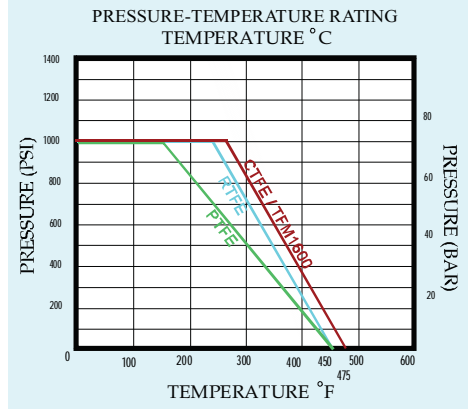

Mid-States Supply Co Inc.

Process Piping / Automation / Controls / Steam Specialties / IT Solutions

www.MidcoOnline.com

Designed, engineered, and manufactured by Haitima Corp.



042110rv2